

HWM3040P

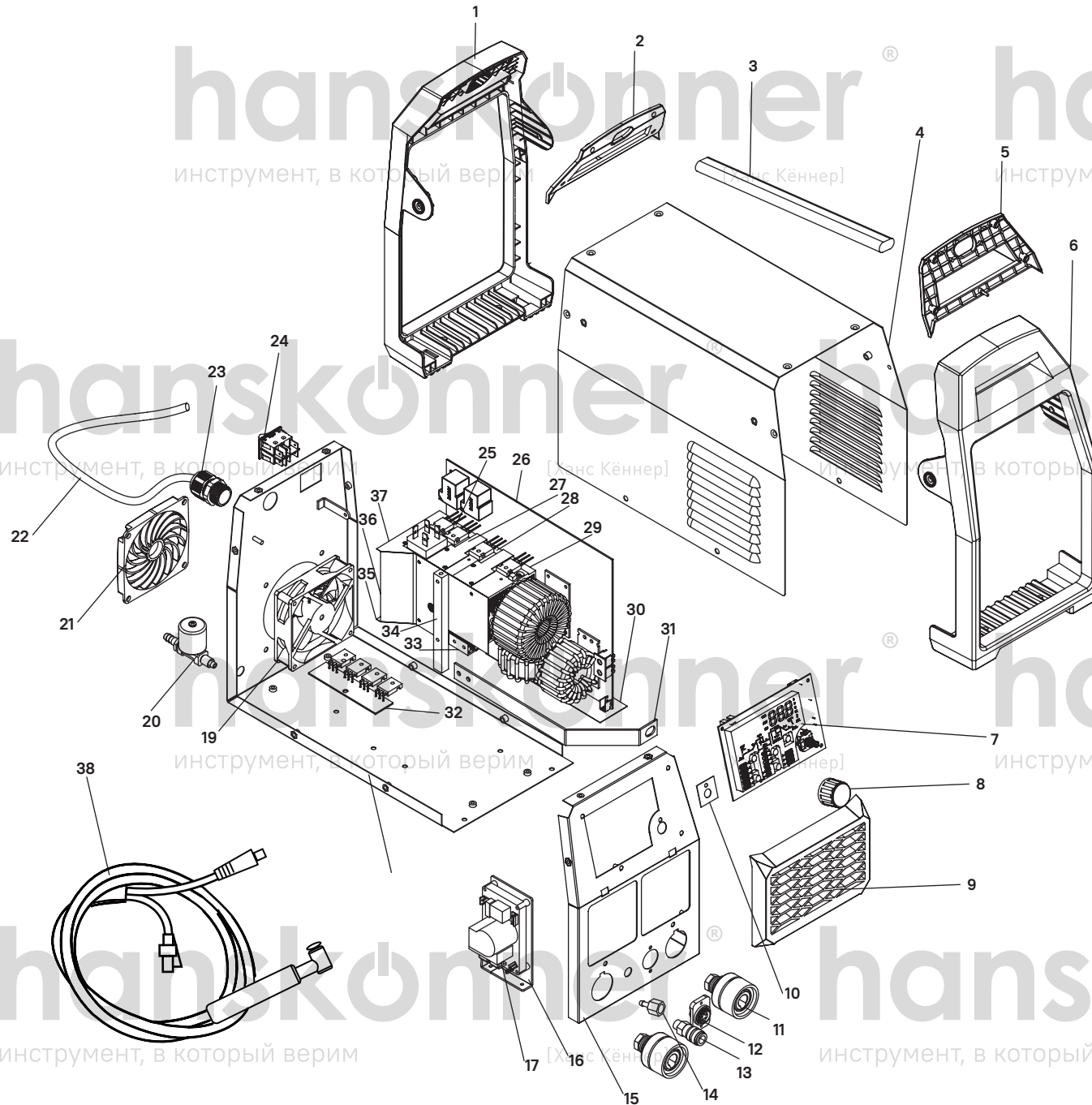

NO	DESCRIPTION
1	BACK PLASTIC COVER
2	BACK PLASTIC PLATE
3	HANDLE
4	MACHINE COVER
5	FRONT PLASTIC PLATE
6	FRONT PLASTIC COVER
7	LED PANEL
8	KNOB
9	VENTILATION COVER
10	INSULATION BOARD
11	QUICK CONNECTOR
12	5 PINS AVIATION SOCKET
13	PNEUMATIC QUICK CONNECTOR
14	PNEUMATIC QUICK HOSE CONNECTOR
15	FRONT PANEL
16	HIGH FREQUENCY PCB SUPPORT
17	HIGH FREQUENCY PCB
18	BASE BOARD
19	FAN
20	SOLENOID VALVE
21	FAN GUARD
22	POWER CABLE
23	CABLE FIXTURES
24	POWER SWITCH
25	RADIATOR
26	MAIN CONTROL BOARD
27	RADIATOR AIR DEFLECTOR
28	RADIATOR
29	RADIATOR
30	INSULATION BOARD
31	ALUMINUM CONNECTIONS
32	RECTIFIER BOARD PCB
33	RADIATOR
34	STAND COLUMN
35	RADIATOR AIR DEFLECTOR
36	RADIATOR AIR DEFLECTOR
37	RADIATOR AIR DEFLECTOR
38	WELDING TORCH TIG 26

HWM3040P MAIN-BOARD

